

NOTES:

CRITICAL HEIGHTS:  
 1. CENTERLINE OF SOIL LINE TRAP INLET TO BE NOT LESS THAN 12 INCHES HIGHER THAN CENTERLINE OF MEDIA TANK INLET FLANGE.  
 2. BASE OF WET WELL TO BE LEVEL OR LOWER THAN BASE OF MEDIA TANK.  
 3. CHLORINATOR INLET ANGLE SHOULD BE 1/4" HIGHER THAN THE OUTLET ANGLE TO ACHIEVE SLOPE ANGLE.

FOUNDATIONS:  
 4. COMPONENTS MAY BE INSTALLED EITHER FORE AND AFT OR ATHWARTSHIPS.  
 5. SECURE TANKS' BASE STANDS ON A FLAT DECK OR BUILT UP FLAT SURFACE.

GRAVITY FLOW PIPING:  
 6. GRAVITY SOIL PIPING LEADING TO MEDIA TANK TO SLOPE NOT LESS THAN 1/4 INCH PER 12 INCHES AND BE EQUIPPED WITH PROPERLY VENTED TRAP AS SHOWN.  
 7. TRAP DEPTH AND TRAP VENT SHOWN FOR 4 INCH SOIL PIPE AND 2 INCH VENT PIPE.

MEDIA TANK VENT PIPING  
 8. DO NOT COMBINE MEDIA TANK VENT WITH ANY OTHER VENT.  
 9. VENT TO TERMINATE NOT LESS THAN 10 FEET ABOVE WEATHER DECK, FROM ANY SOURCE OF IGNITION AND FROM ANY VENTILATION AIR INLET.  
 10. VENT TO TERMINATE HIGH RATHER THAN LOW, SINCE VENTED AIR IS WARMER THAN SURROUNDING AIR AND WILL RISE.  
 11. HORIZONTAL OFFSETS IN MEDIA TANK VENT MUST BE SLOPED NOT LESS THAN 1/2 INCH PER 12 INCHES SO THAT CONDENSATE WILL DRAIN TO MEDIA TANK.  
 12. FLAME SCREEN IS NOT RECOMMENDED. IT WILL PLUG WITH LINT AND REQUIRE FREQUENT CLEANING. IF A FLAME SCREEN MUST BE USED, SCREEN TO BE TWO PIPE SIZES LARGER THAN VENT PIPE.

EMERGENCY BYPASS DISCHARGE:  
 13. AN EMERGENCY BYPASS DISCHARGE IS REQUIRED TO PROVIDE THE USE OF SANITARY FACILITIES IN CASE OF EQUIPMENT MALFUNCTION.  
 14. MOUNT SEWAGE INLET AND EMERGENCY BYPASS GATE VALVES WITH STEMS IN AN UPRIGHT VERTICAL POSITION.

BLOWER DISCHARGE PIPING:  
 15. THE FIRST SIX FEET OF PIPE TO BE METAL. AT THE HIGHEST POINT, WELL ABOVE MEDIA TANKTOP, DRILL 3/64" ANTI-SIPHON HOLE.

MAINTENANCE AND CLEARANCE REQUIREMENTS:  
 16. ALLOW AT LEAST 28 INCHES CLEARANCE ABOVE MEDIA TANK COVER TO VENT SPOOL FLANGED CONNECTION TO PERMIT REMOVAL OF COVER FOR INTERNAL REPAIR.  
 17. ALLOW AT LEAST 12 INCHES CLEARANCE ABOVE CHLORINE TABLET REFILL TUBES FOR TUBE REMOVAL.

GENERAL PIPING REQUIREMENTS:  
 18. CONNECTING PIPING AND INSTALLATION SHALL BE IN ACCORDANCE WITH REQUIREMENTS OF APPLICABLE REGULATORY BODIES.  
 19. FLEX OR HOSE CONNECTIONS RECOMMENDED FOR HOOK UP TO MEDIA AND WET WELL TANKS TO RELIEVE STRESS ON TANKS.  
 20. RECOMMENDED PIPING MATERIAL IS SCHEDULE 80 PVC.

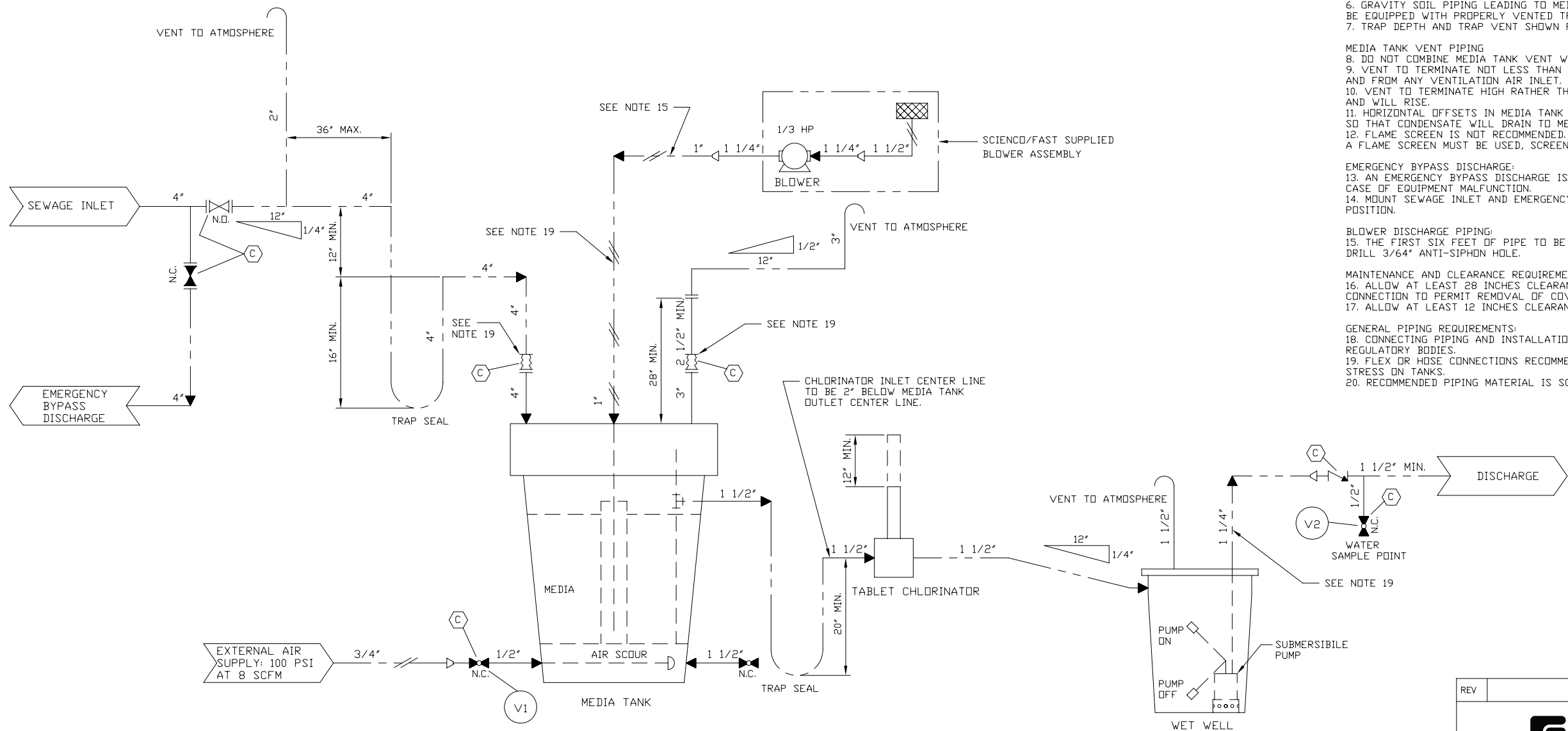

**LEGEND:**

- CUSTOMER PROCESS PIPING
- CUSTOMER AIR PIPING
- N.O. NORMALLY OPEN
- N.C. NORMALLY CLOSED
- || FLANGED CONNECTION
- ▷ REDUCER
- ⊗ AIR FILTER
- ⊗ GATE VALVE- FLANGED
- ⊗ BALL VALVE- SCREWED
- ⊗ CHECK VALVE- SCREWED
- ⊗ FLEXIBLE CONNECTION
- ⊗ CUSTOMER SUPPLIED VALVE

NOTE: DRAWING DEPICTS SYSTEM IN NORMAL RUN POSITION.

MANUAL VALVE POSITION CHART				
VALVE NO.	VALVE FUNCTION	OPERATING POSITION		
		RUN	SCOUR	DRAIN
V1	AIR SCOUR	CLOSED	OPEN	OPEN
V2	WATER SAMPLE	CLOSED	CLOSED	

BLOWER & PUMP OPERATION CHART				
MOTOR CALLOUT	HP	OPERATING POSITION		
		RUN	SCOUR	DRAIN
BLOWER	1/3	ON	OFF	
PUMP	1/3	ON	OFF	ON

REV	DESCRIPTION	BY	DATE
 <b>SCIENTO/FAST®</b> 12977 MAURER INDUSTRIAL DRIVE SUNSET HILLS, MO 63127-1515 U.S.A. PHONE: 314-645-6540 FAX: 314-645-6131			
THIS DRAWING AND INFORMATION CONTAINED THEREIN IS THE PROPERTY OF SCIENTO/FAST SYSTEMS AND IS LOANED WITH THE EXPRESSED AGREEMENT THAT IT WILL NOT BE REPRODUCED, COPIED, OR OTHERWISE DISTRIBUTED, DIRECTLY OR INDIRECTLY, AND WILL NOT BE USED IN WHOLE OR IN PART, TO FURNISH ANY INFORMATION FOR THE MANUFACTURING OF EQUIPMENT OR APPARATUS WITHOUT WRITTEN PERMISSION OF SCIENTO/FAST SYSTEMS FIRST OBTAINED AND SPECIFIC TO EACH CASE.			
SYSTEM		FAST SEWAGE TREATMENT	
CUSTOMER			
TITLE			
SYSTEM PIPING DIAGRAM & INSTALLATION DATA			
SCALE	DRAWN	CHECKED	APPROVED
NONE	CEG		
SIZE	PREV. ASSY.	PLOT SCALE	DATE
D		1:1	2/16/06
CONTRACT NO.	MODEL NO.	DRAWING NO.	SHEET NO.
	L2X	CU000	1 OF 1
			0

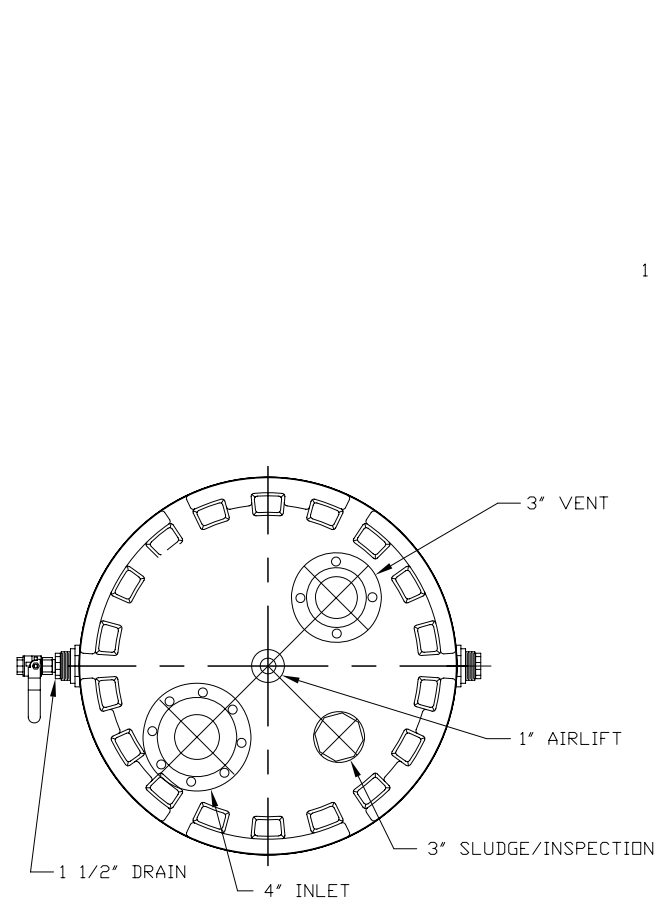

PLAN VIEW

2'-7 1/2"

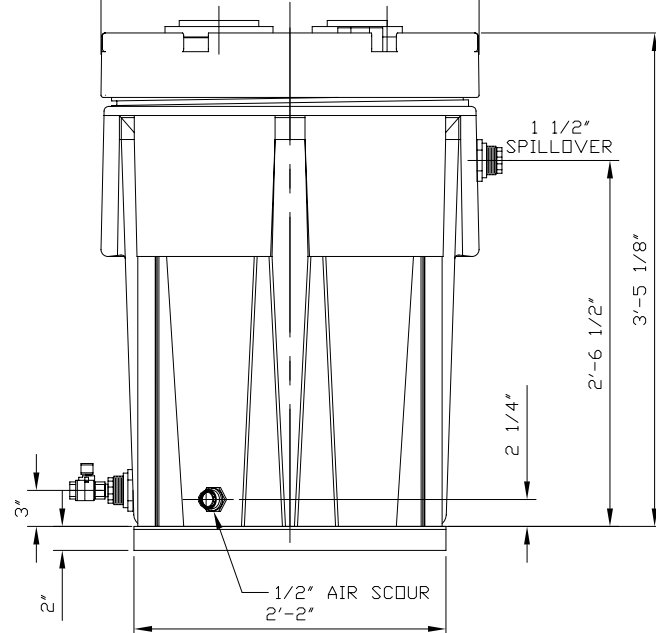

ELEVATION

MEDIA TANK

EST. WT.: 150 LBS. SHIPPING  
EST. WT.: 835 LBS. OPERATING

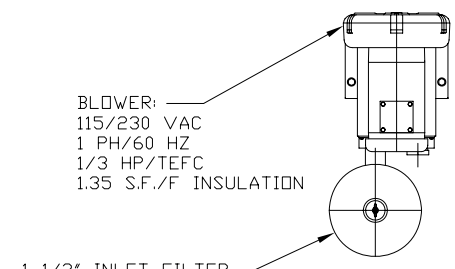

PLAN VIEW

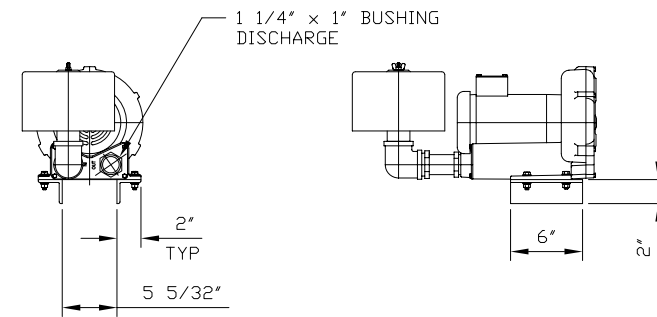

ELEVATION

END VIEW

BLOWER ASSEMBLY

EST. WT.: 51 LBS.

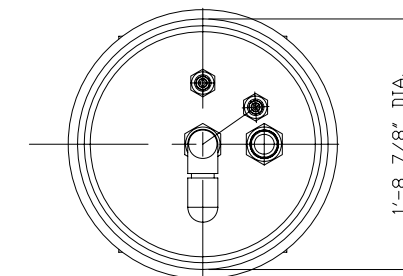

PLAN VIEW

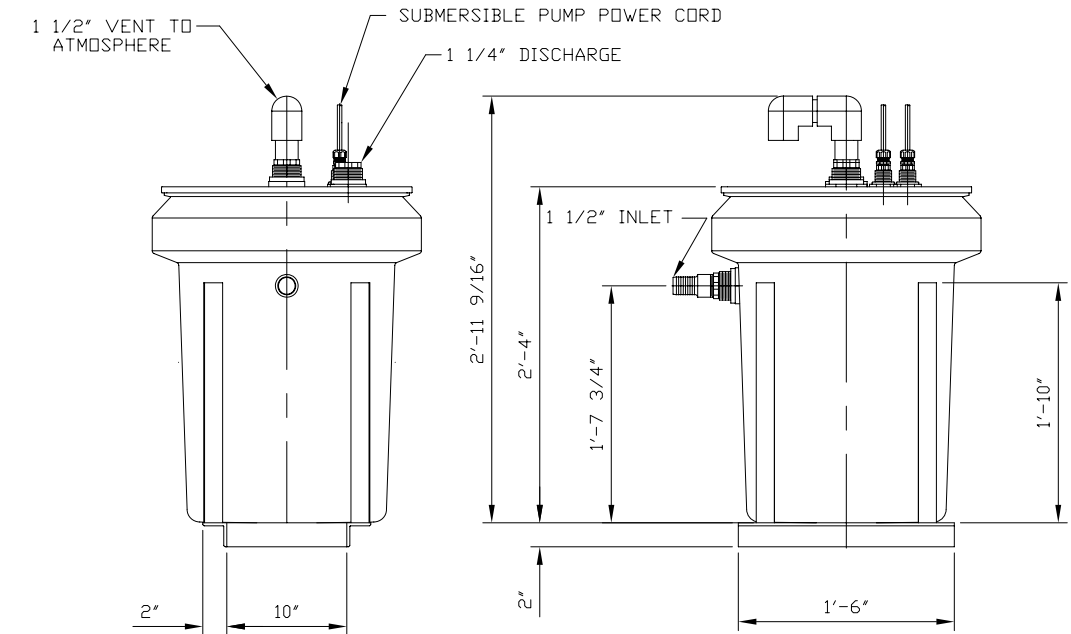

ELEVATION

END VIEW

WET WELL

EST. WT.: 58 LBS. SHIPPING  
EST. WT.: 225 LBS. OPERATING

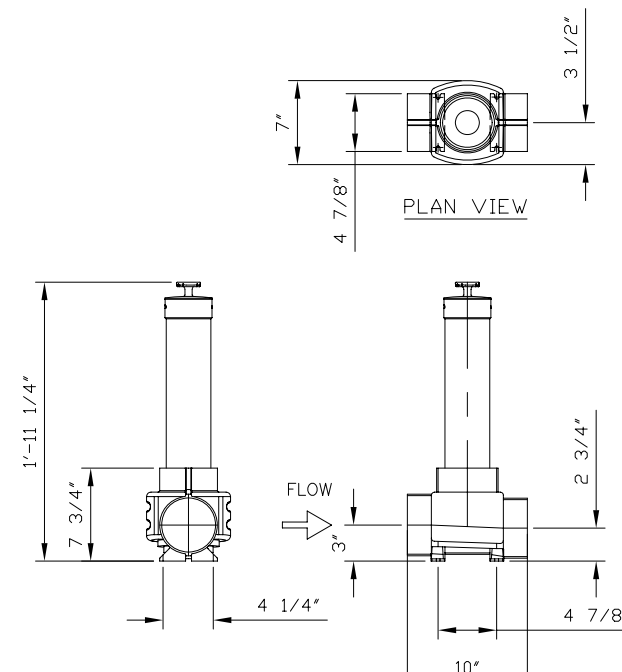

PLAN VIEW

END VIEW

ELEVATION

CHLORINATOR ASSEMBLY

EST. WT.: 26 LBS.

REV	DESCRIPTION	BY	DATE
 <b>SCIENCO/FAST®</b> 12977 MAURER INDUSTRIAL DRIVE SUNSET HILLS, MO 63127-1515 U.S.A. PHONE: 314-645-6540 FAX: 314-645-6131			
THIS DRAWING AND INFORMATION CONTAINED THEREIN IS THE PROPERTY OF SCIENCO/FAST SYSTEMS AND IS LOANED WITH THE EXPRESSED AGREEMENT THAT IT WILL NOT BE REPRODUCED, COPIED, OR OTHERWISE DISTRIBUTED, DIRECTLY OR INDIRECTLY, AND WILL NOT BE USED IN WHOLE OR IN PART, TO FURNISH ANY INFORMATION FOR THE MANUFACTURING OF EQUIPMENT OR APPARATUS WITHOUT WRITTEN PERMISSION OF SCIENCO/FAST SYSTEMS FIRST OBTAINED AND SPECIFIC TO EACH CASE.			
SYSTEM		FAST SEWAGE TREATMENT	
CUSTOMER			
TITLE			
L2X DIMENSIONS AND WEIGHTS			
SCALE	DRAWN	CHECKED	APPROVED
NONE	CEG		
SIZE	PREV. ASSY.	PLOT SCALE	DATE
D		1:1	3/09/06
CONTRACT NO.	MODEL NO.	DRAWING NO.	SHEET NO.
	L2X	CU001	1 OF 1
			REV 0

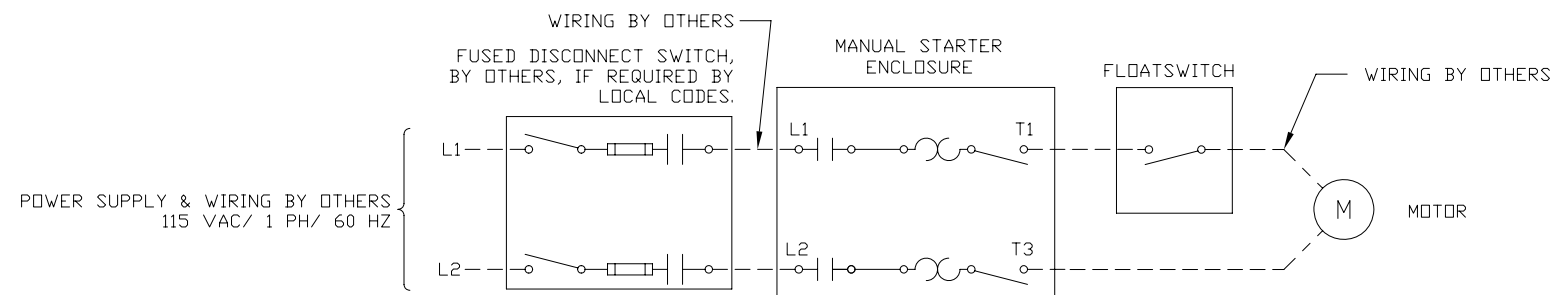

SINGLE PHASE PUMP WIRING DIAGRAM (STANDARD)

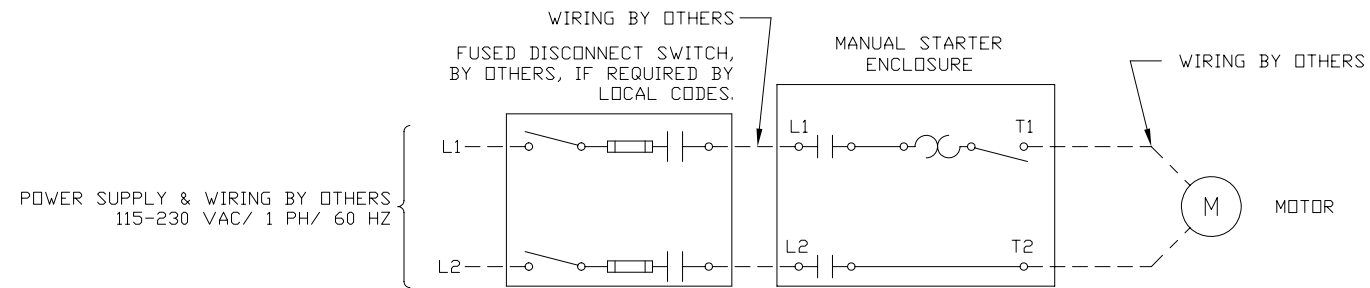

SINGLE PHASE BLOWER WIRING DIAGRAM (STANDARD)

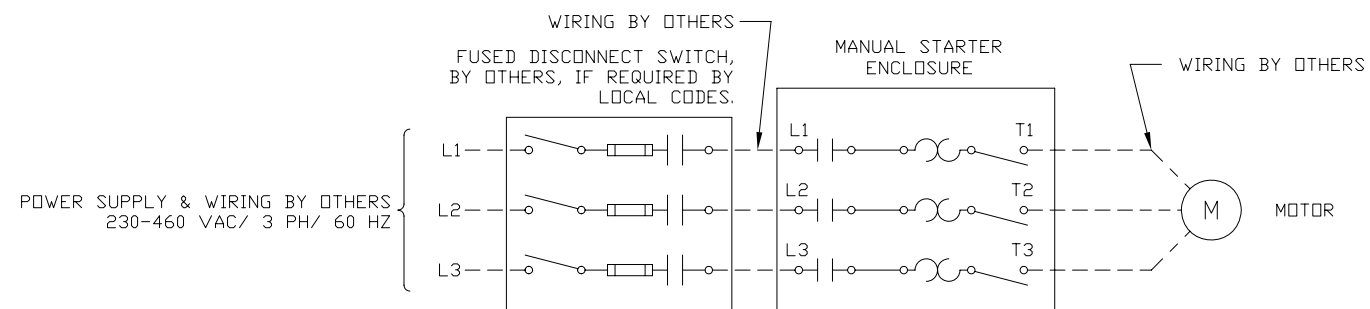

THREE PHASE BLOWER WIRING DIAGRAM (OPTIONAL)

NOTES:

1. FEEDER CABLE, OVERCURRENT PROTECTION AND WIRING OF REMOTE DEVICES BY OTHERS AND TO BE IN ACCORDANCE WITH THE REQUIREMENTS OF APPLICABLE REGULATORY BODIES.
2. STARTER ENCLOSURE, NEMA 4/4X
3. STARTER COMPONENTS PER IEEE45

REV	DESCRIPTION	BY	DATE
 <b>SCIENCEO/FAST®</b> 12977 MAURER INDUSTRIAL DRIVE SUNSET HILLS, MO 63127-1515 U.S.A. PHONE: 314-645-6540 FAX: 314-645-6131			
THIS DRAWING AND INFORMATION CONTAINED THEREIN IS THE PROPERTY OF SCIENCEO/FAST SYSTEMS AND IS LOANED WITH THE EXPRESSED AGREEMENT THAT IT WILL NOT BE REPRODUCED, COPIED, OR OTHERWISE DISTRIBUTED, DIRECTLY OR INDIRECTLY, AND WILL NOT BE USED IN WHOLE OR IN PART, TO FURNISH ANY INFORMATION FOR THE MANUFACTURING OF EQUIPMENT OR APPARATUS WITHOUT WRITTEN PERMISSION OF SCIENCEO/FAST SYSTEMS FIRST OBTAINED AND SPECIFIC TO EACH CASE.			
SYSTEM		FAST SEWAGE TREATMENT	
CUSTOMER		HOUSCO PACIFIC CO.	
TITLE			
BLOWER & PUMP WIRING DIAGRAMS			
SCALE	DRAWN	CHECKED	APPROVED
NONE	CEG		
SIZE	PREV. ASSY.	PLOT SCALE	DATE
D		1:1	3/10/06
CONTRACT NO.	MODEL NO.	DRAWING NO.	SHEET NO.
	L2X	EL500	1 OF 1
			REV
			0